

## 5 Inch Pro Series Grates

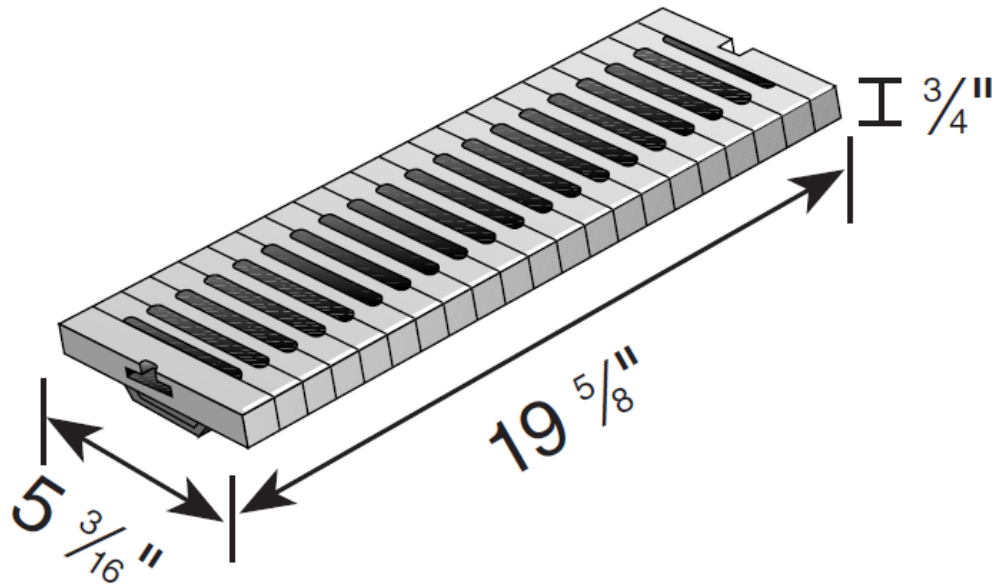

Part #: 828  
 Material: High Impact Glass Reinforced Nylon  
 Color: #828( Gray)  
 Fits: 5" Pro Series Channel, Part# 820 ( takes 1 grate) and  
 Part# 800 ( takes 2 grates)  
 Grate Opening: 1/2" x 3"  
 Open Surface Area: 17.50sq. Inch per Ft.  
 Head Pressure / Flow Rate:  
Head (inches) - Max Flow  
 1" = 75.71 GPM  
 0.5" = 53.53 GPM  
 Weight per each: 2.35 lbs.  
 Screw: #829 Stainless Steel Screw, 4 per grate.

UV Inhibitors



### **Class C**

- Loads of 176-325 psi.
- Recommended for heavy-duty pneumatic tire forklifts and tractor trailers at speeds less than 20 m.p.h., H-20 rated.

## ADA Compliant