

8" ROUND GRATE

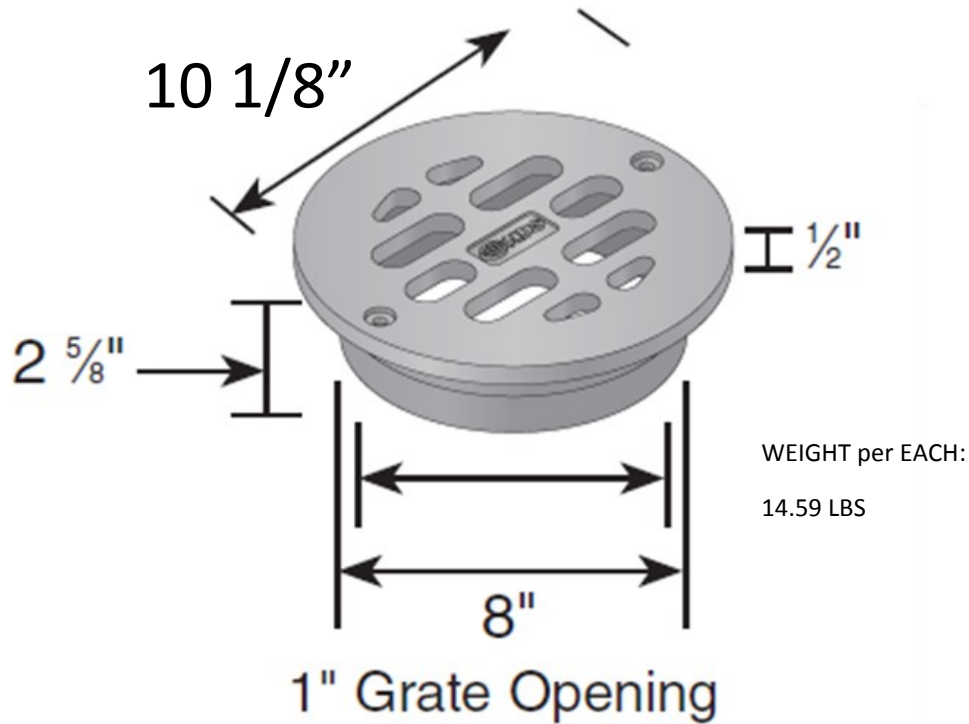

Material : Ductile Iron
 Colors: Black (D8)
 Fits: 8" Corrugated and Sewer and Drain pipe
 This is not a custom grate and qualifies for normal NDS freight Terms
 Opening: 13.98 in² open space
 Will accommodate 42.77 gallons per minute with 1/2" of head

Load Recommendation Guide



Class D

- Loads of 326-575 psi.
- Recommended for heavy-duty hard tire forklifts at speeds less than 20 m.p.h., H-20 rated.



**DRAINAGE
SOLUTIONS, INC**

(317) 346-4110

www.drainagesolutionsinc.com

