

FLO-WELL[®] SURFACE DRAIN INLET

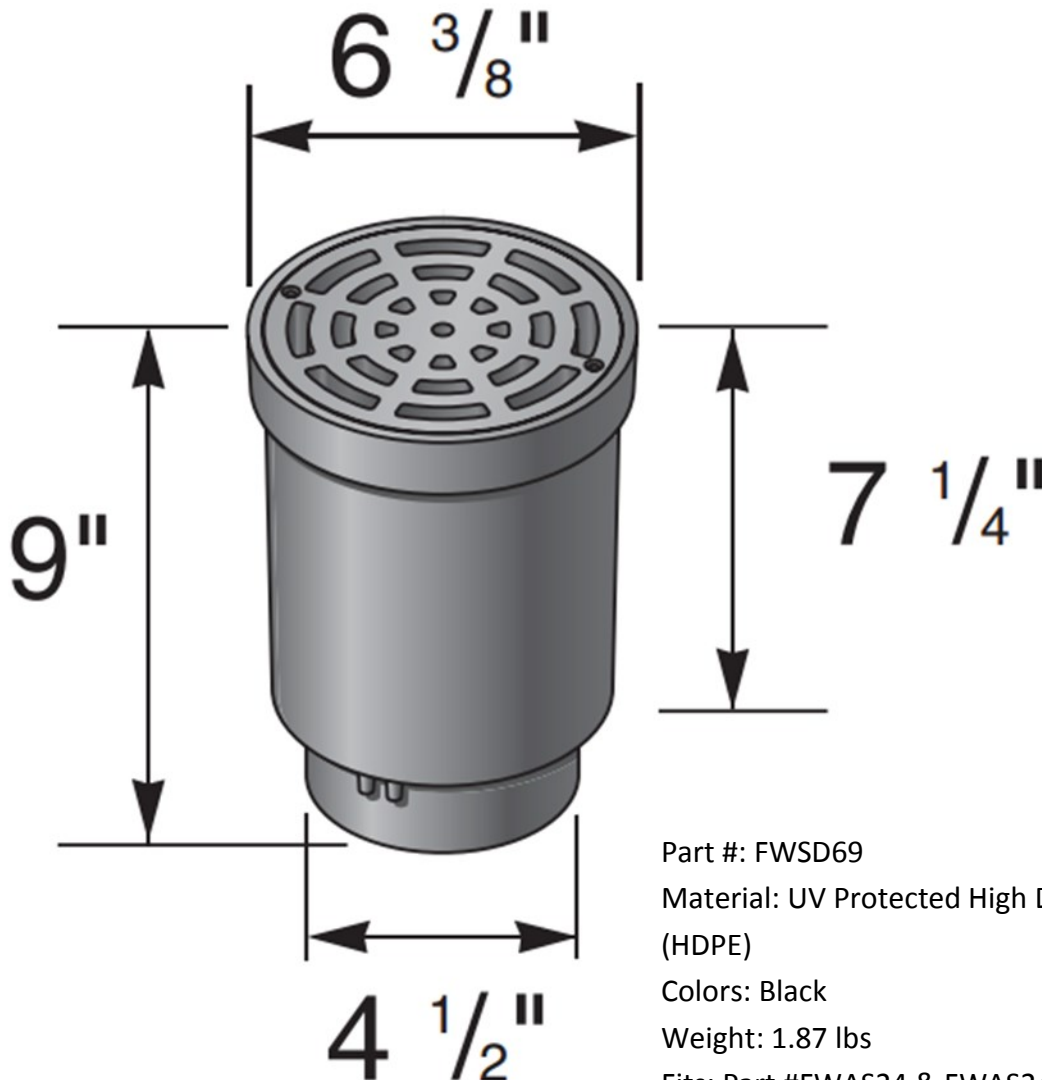

Part #: FWSD69

Material: UV Protected High Density Polypropylene (HDPE)

Colors: Black

Weight: 1.87 lbs

Fits: Part #FWAS24 & FWAS24C

Open Surface Area: 8.22 square inches

Flow rate with 1/2" of head: 25.15 GPM

Flow rate with 1" of head: 35.56 GPM



(317) 346-4110

DRAINAGE SOLUTIONS, INC. www.drainagesolutionsinc.com

