

NDS®

We put water in its place



(317) 346-4110

www.drainagesolutionsinc.com

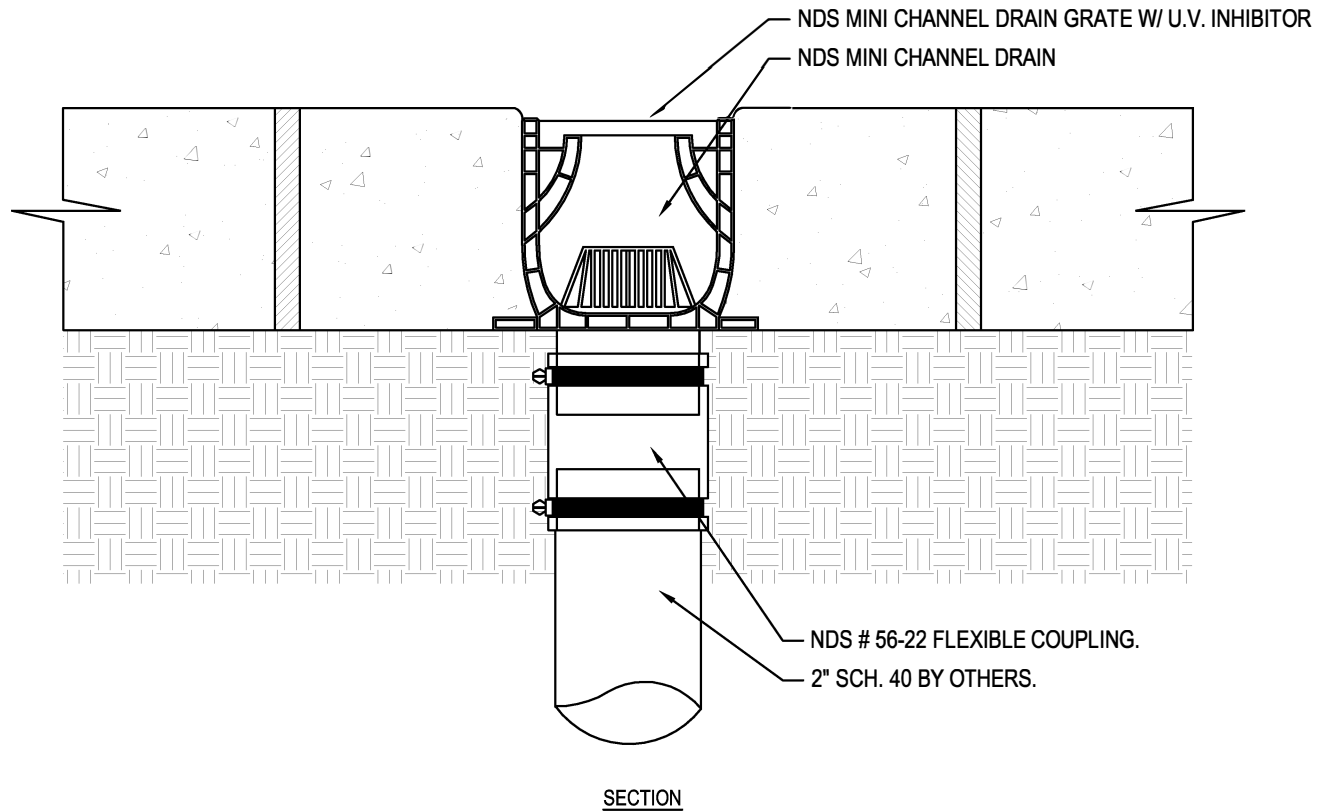

NOTES:

1. EXISTING SOILS SHOULD BE EVALUATED TO ENSURE PROPER STRUCTURAL AND PERMEABILITY PROPERTIES.
2. INSTALLATION TO BE COMPLETED IN ACCORDANCE WITH MANUFACTURER'S SPECIFICATIONS.
3. DO NOT SCALE DRAWING.
4. THIS DRAWING IS INTENDED FOR USE BY ARCHITECTS, ENGINEERS, CONTRACTORS, CONSULTANTS AND DESIGN PROFESSIONALS FOR PLANNING PURPOSES ONLY.
5. ALL INFORMATION CONTAINED HEREIN WAS CURRENT AT THE TIME OF DEVELOPMENT BUT MUST BE REVIEWED AND APPROVED BY THE PRODUCT MANUFACTURER TO BE CONSIDERED ACCURATE.

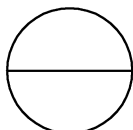

MINI CHANNEL DRAIN SYSTEM

#550 2" SCH. 40 BTM. OUT 1

