



PIPE TOOLS & VISES  
SINCE 1896

## RCORP3 Smooth Jaw Wrench with Corp Stop Key Disc

### Instructions

#### Instructions:

1. Align key on back side of disc with channel in wrench handle.
2. Insert lock washer and screw.
3. Tighten screw with hex key/Allen wrench.

#02117 includes #02114 RCORP wrench plus #02119 corp stop key disc assembly.

#02119 Corp Stop Key Disc Assembly includes replacement disc with 3 slots, lock washer and screw. RCORP wrench sold separately.

**Slot sizes:** .450", .390", .312" for use on standard and ball valve corp stop keys.

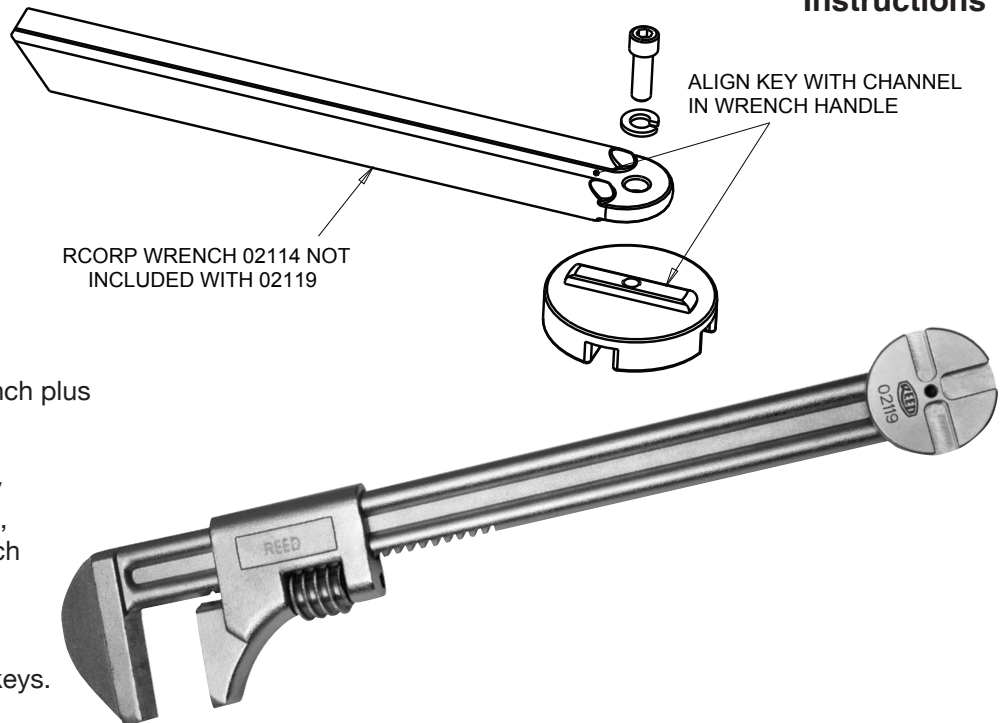

Reed Manufacturing Company  
1425 West 8th Street  
Erie, PA 16502 USA

**QUALITY**  
& Service  
that Last a Lifetime

Phone: 800-666-3691 or 814-452-3691  
Fax: 800-456-1697 or 814-455-1697  
www.reedmfgco.com

0817-52120



PIPE TOOLS & VISES  
SINCE 1896

## RCORP3 Smooth Jaw Wrench with Corp Stop Key Disc

### Instructions

#### Instructions:

1. Align key on back side of disc with channel in wrench handle.
2. Insert lock washer and screw.
3. Tighten screw with hex key/Allen wrench.

#02117 includes #02114 RCORP wrench plus #02119 corp stop key disc assembly.

#02119 Corp Stop Key Disc Assembly includes replacement disc with 3 slots, lock washer and screw. RCORP wrench sold separately.

**Slot sizes:** .450", .390", .312" for use on standard and ball valve corp stop keys.

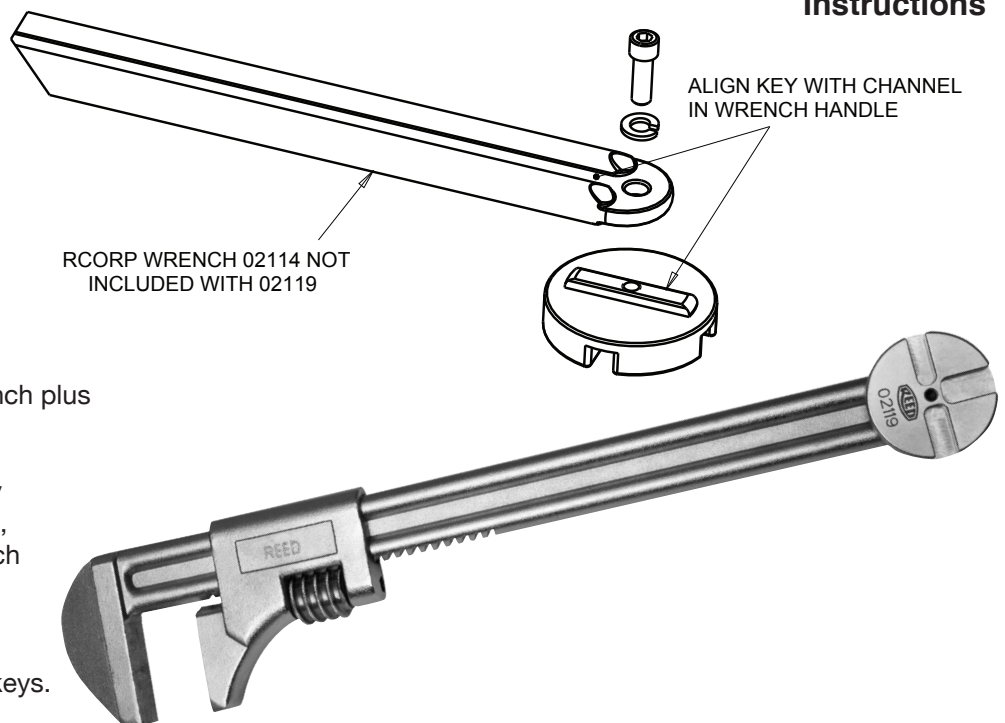

Reed Manufacturing Company  
1425 West 8th Street  
Erie, PA 16502 USA



(317) 346-4110

www.drainagesolutionsinc.com

Phone: 800-666-3691 or 814-452-3691  
Fax: 800-456-1697 or 814-455-1697  
www.reedmfgco.com

0817-52120